

STREET AND STORM SEWER PLAN
Knob View Estates, Northern Addition
SECTION 1

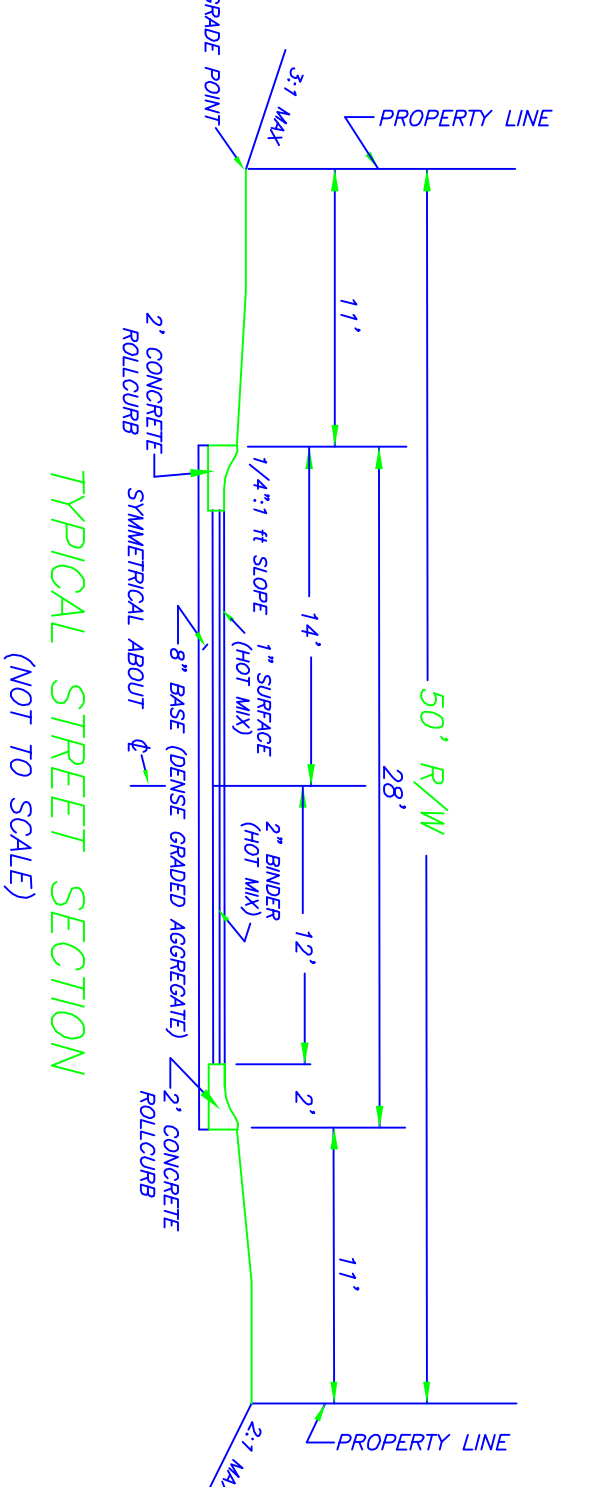

- LEGEND:**
- DENOTES PROPOSED CURB INLET
 - DENOTES PROPOSED YARD INLET
 - DENOTES PROPOSED HEADWALL
 - DENOTES EXISTING SANITARY SEWER MANHOLE
 - DENOTES PROPOSED SANITARY SEWER MANHOLE
 - DENOTES TEMPORARY ROCK CHECK DAM
 - DENOTES EXISTING SANITARY SEWER LINE
 - DENOTES PROPOSED SANITARY SEWER LINE
 - DENOTES EXISTING CONTOUR
 - DENOTES EXISTING CONTOUR

- NOTES:**
- (1) All street and storm sewer construction shall meet Clark County specifications.
 - (2) Contractor must field verify all existing utilities prior to construction. Call 1-800-382-5544 for utility locations.
 - (3) All street and building pad fill areas shall be compacted to 95% proctor.
 - (4) High density polyethylene pipe may be substituted for reinforced concrete pipe in yard areas only.
 - (5) Upkeep of the detention facility shall be maintained by the Home Owner's Association.
 - (6) Any construction in floodway will require a permit from the Department of Natural Resources.
 - (7) All rock check dams are to be removed after completion of construction.

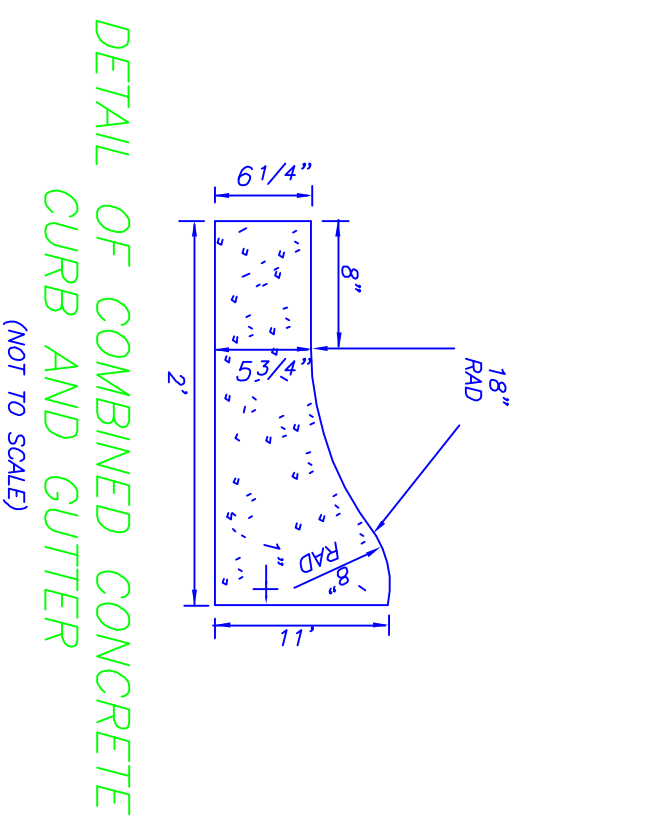

Knob View Estates Section 1 Storm Sewer Values

UPSTREAM STRUCTURE	DOWNSTREAM STRUCTURE	AREA	Q10	Q10 SUM	Q100	Q100 SUM	DIAMETER	LENGTH	SLOPE	CAPACITY
#	GRADE INV.	#	(ACRES)	(cfs)	(cfs)	(cfs)	(in.)	(ft.)	(%)	(cfs)
1	524.00	1	0.17	0.46	0.62	0.62	12	26.0	10.46	11.52
2	524.00	2	0.17	0.46	0.62	0.62	12	26.0	10.46	11.52
3	524.00	3	0.17	0.46	0.62	0.62	12	26.0	10.46	11.52
4	524.00	4	0.17	0.46	0.62	0.62	12	26.0	10.46	11.52
5	524.00	5	0.17	0.46	0.62	0.62	12	26.0	10.46	11.52
6	524.00	6	0.17	0.46	0.62	0.62	12	26.0	10.46	11.52
7	524.00	7	0.17	0.46	0.62	0.62	12	26.0	10.46	11.52
8	524.00	8	0.17	0.46	0.62	0.62	12	26.0	10.46	11.52
9	524.00	9	0.17	0.46	0.62	0.62	12	26.0	10.46	11.52
10	524.00	10	0.17	0.46	0.62	0.62	12	26.0	10.46	11.52
11	524.00	11	0.17	0.46	0.62	0.62	12	26.0	10.46	11.52
12	524.00	12	0.17	0.46	0.62	0.62	12	26.0	10.46	11.52
13	524.00	13	0.17	0.46	0.62	0.62	12	26.0	10.46	11.52
14	524.00	14	0.17	0.46	0.62	0.62	12	26.0	10.46	11.52
15	524.00	15	0.17	0.46	0.62	0.62	12	26.0	10.46	11.52
16	524.00	16	0.17	0.46	0.62	0.62	12	26.0	10.46	11.52
17	524.00	17	0.17	0.46	0.62	0.62	12	26.0	10.46	11.52
18	524.00	18	0.17	0.46	0.62	0.62	12	26.0	10.46	11.52
19	524.00	19	0.17	0.46	0.62	0.62	12	26.0	10.46	11.52
20	524.00	20	0.17	0.46	0.62	0.62	12	26.0	10.46	11.52

BLANKENBEKER & SON
LAND SURVEYORS INC., P.C.
 422 MERIDIAN AVENUE, JEFFERSONVILLE, INDIANA
 TELEPHONE (812) 282-4183 P.O. BOX 157 47131-0157
 WWW.BLANKENBEKERANDSON.COM

SCALE: 1"=50 FEET DATE: 4 JUNE 2004
 BR: C.B.H. 108 # 17.221